

Kann die B44 ein Boulevard werden?



# Wie viel Autoverkehr verträgt ein Boulevard?



# Welche Eigenschaften machen eine Straße zum Boulevard?



# Proportionen, breite Seitenräume, Raumkanten, Bäume

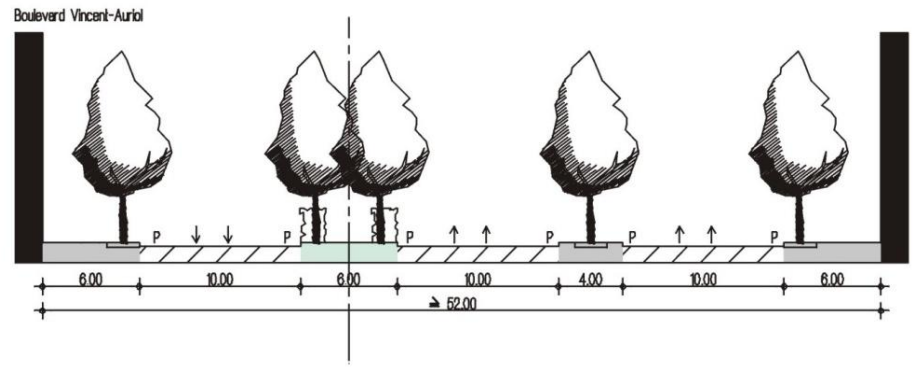
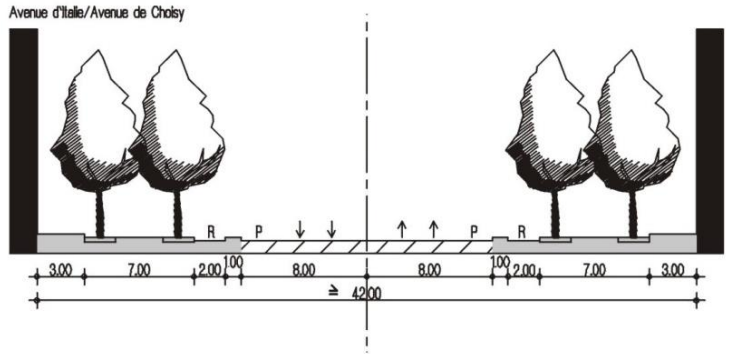
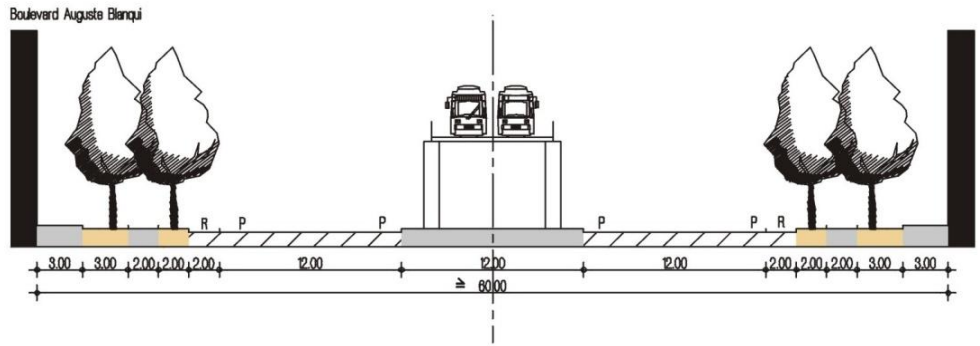

# Aufenthaltsqualität entlang niveaugleicher Hochleistungsstraße



Konrad-Adenauer-Straße Stuttgart

# Beste Adresse trotz sehr starkem Autoverkehr



B1 in Dortmund

# Landsberger Allee Berlin: trotz sechs Baumreihen kein Boulevard!

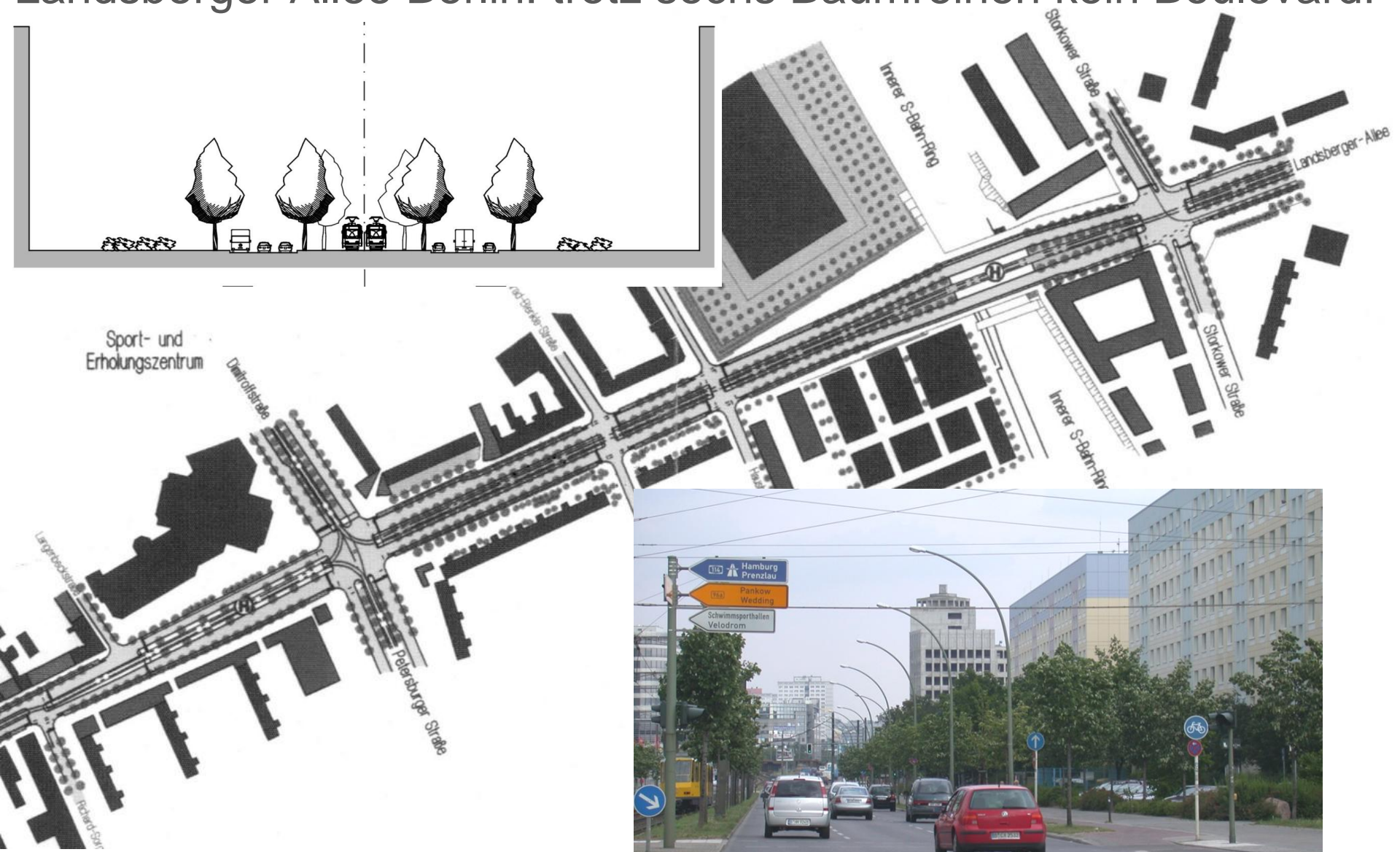
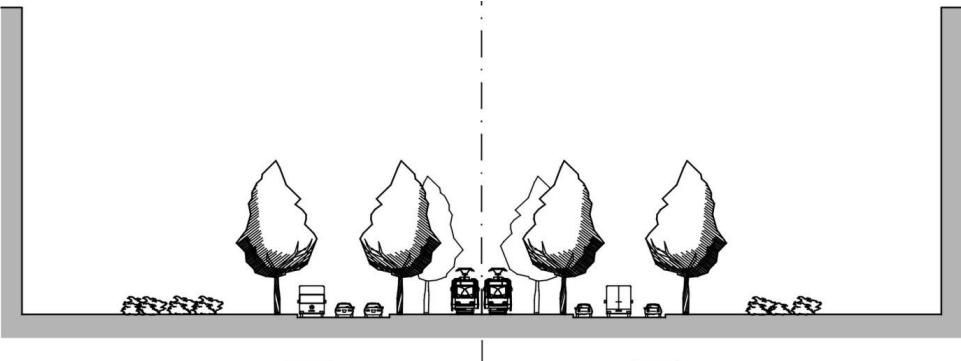

# Hochleistungsstraße Landsberger Allee Berlin





# Boulevard



# Boulevard



Linearität

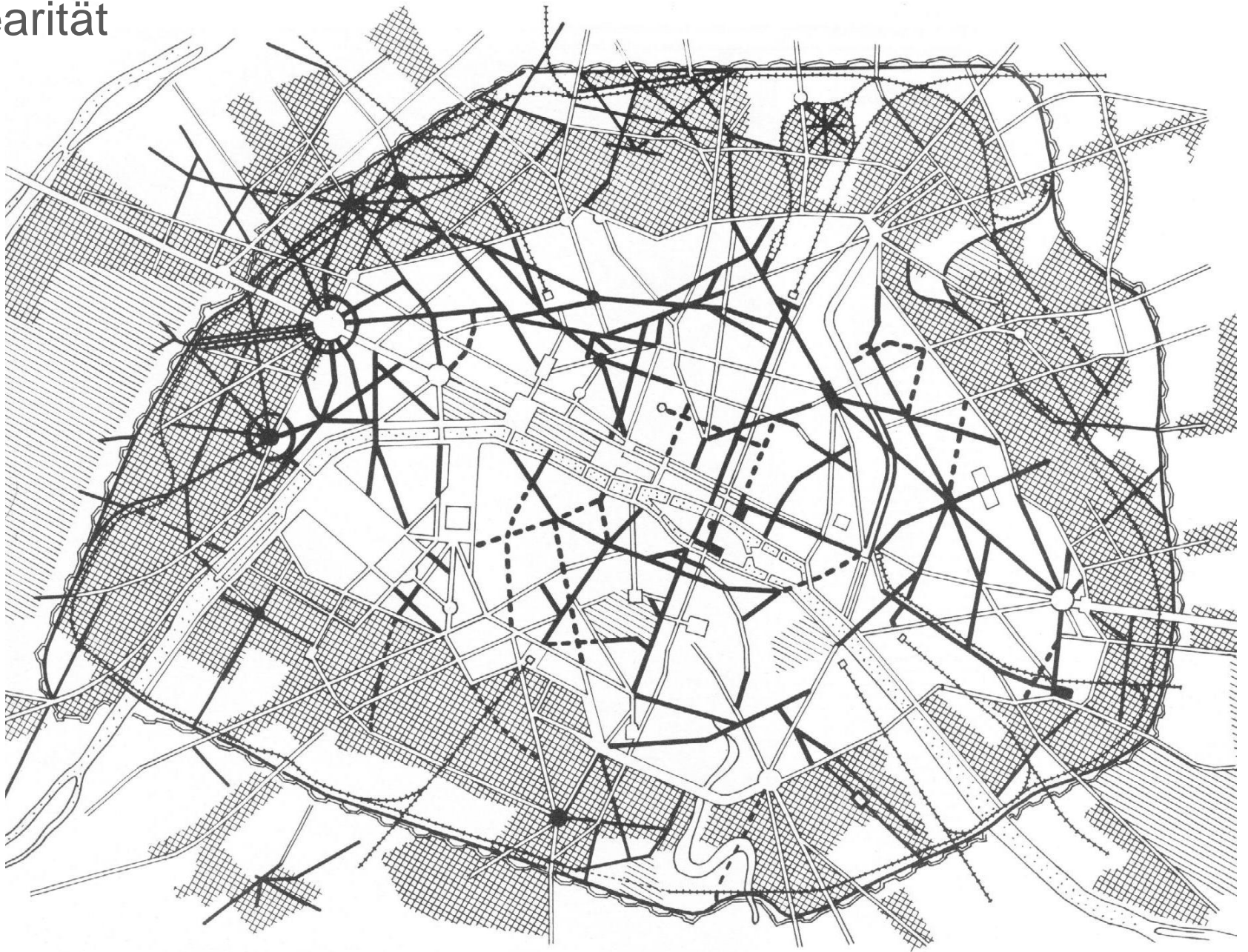

HJPplaner

# Orientierung und identitätsstiftende Ausstattung (Beleuchtung)



Karl-Marx-Allee Berlin

# Flexible Mitte, harte Kanten

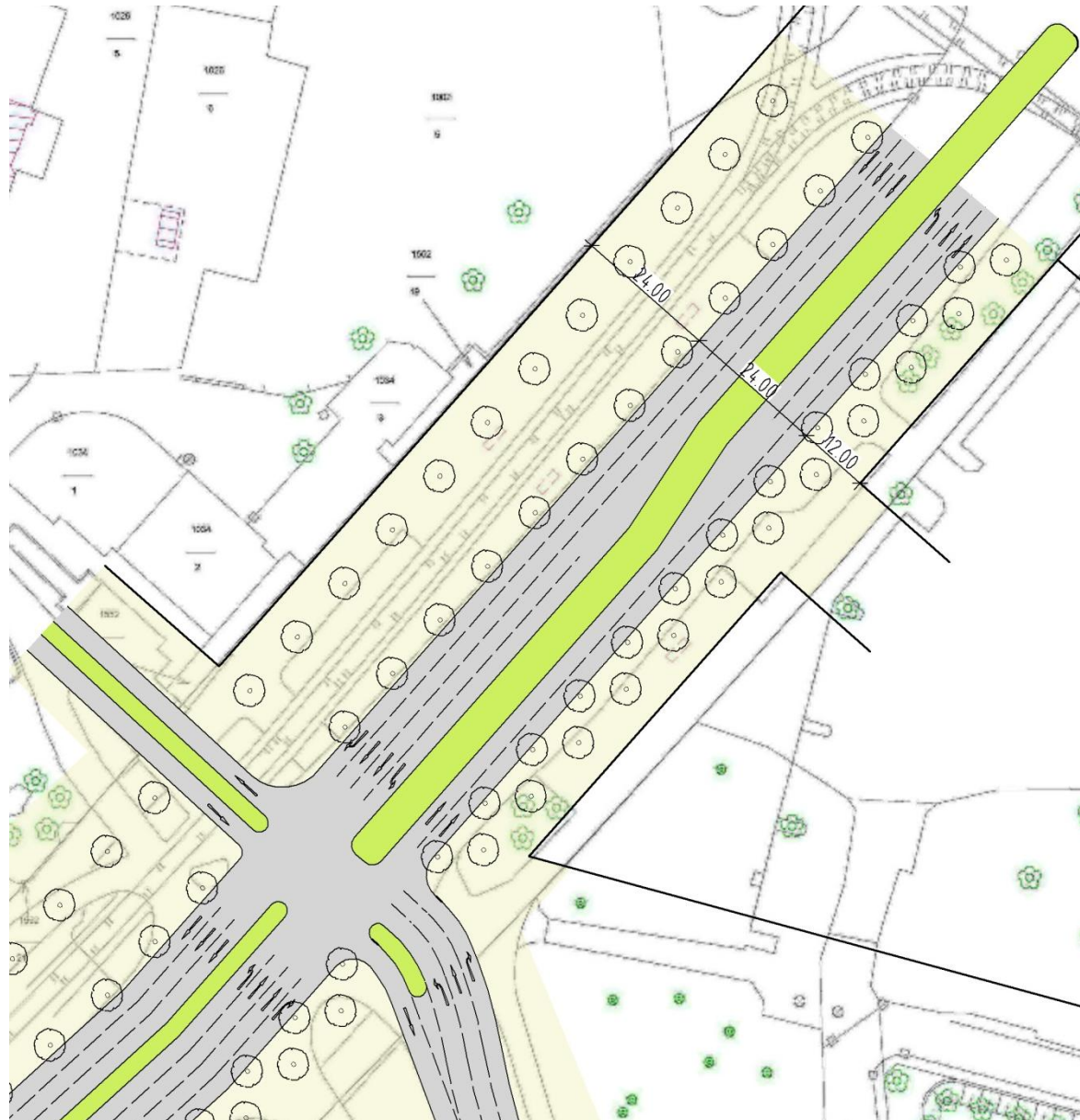

# Vernetzung mit den seitlichen Strukturen

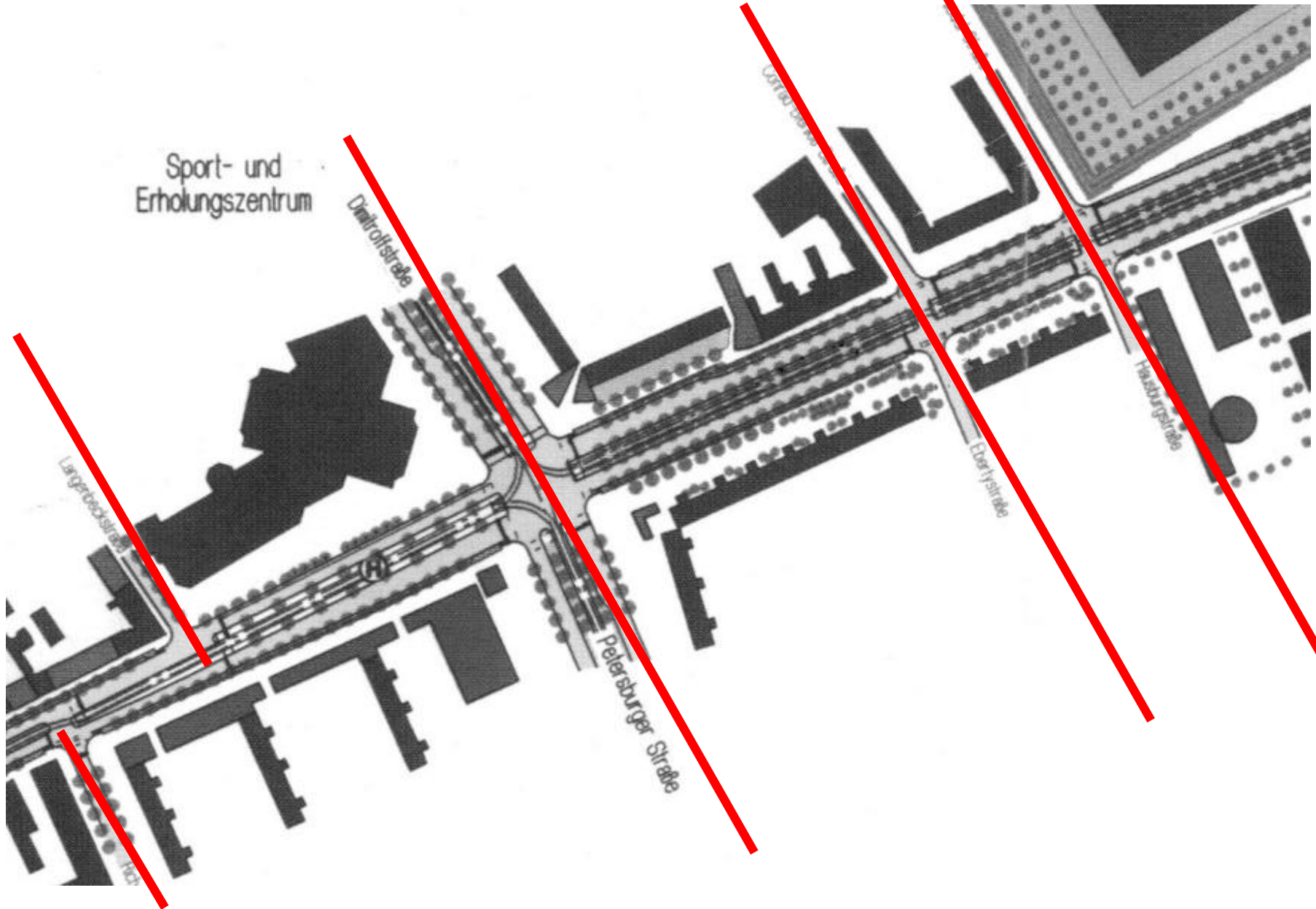

# B44 Boulevard

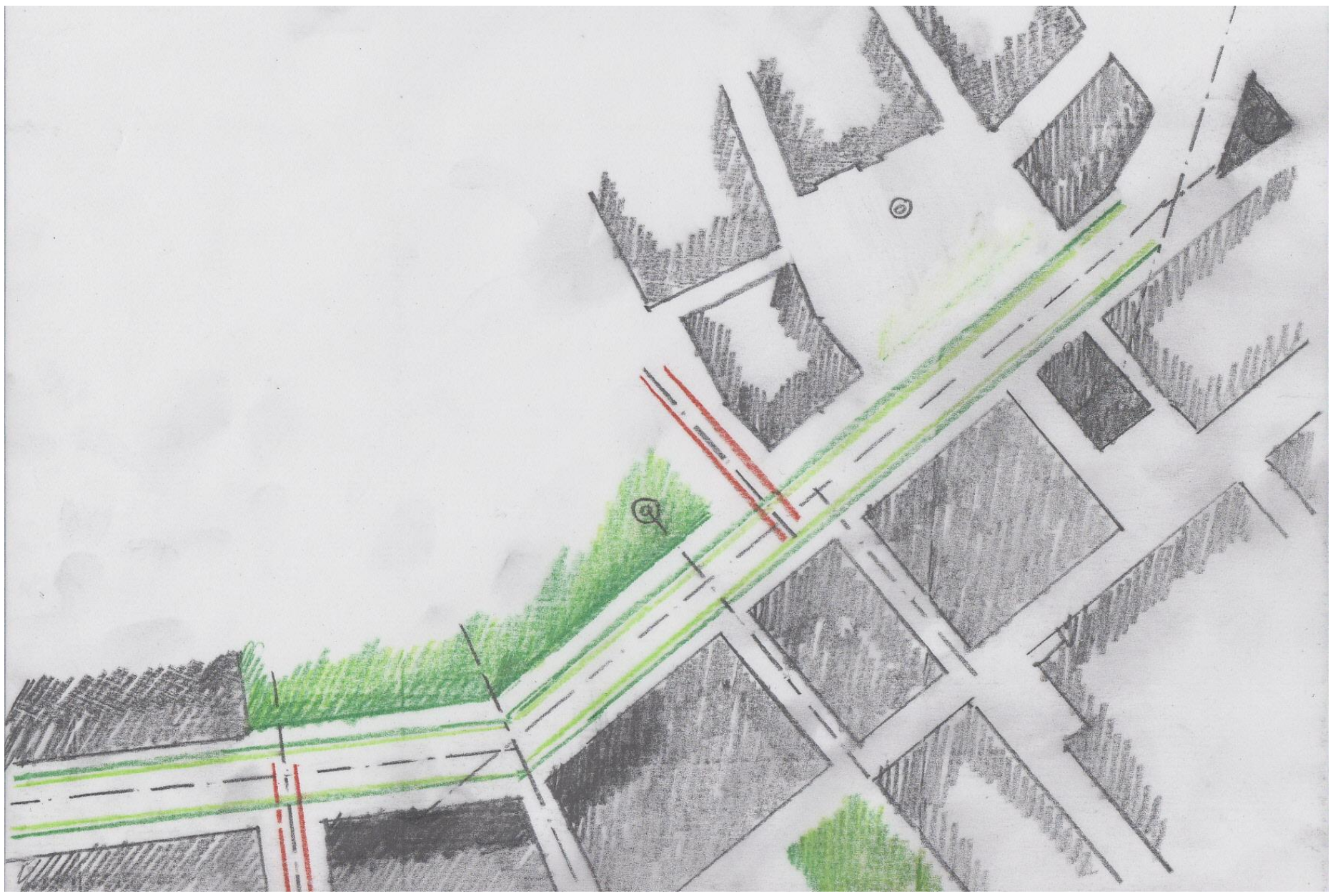

# B44 Optimaler Boulevard-Querschnitt

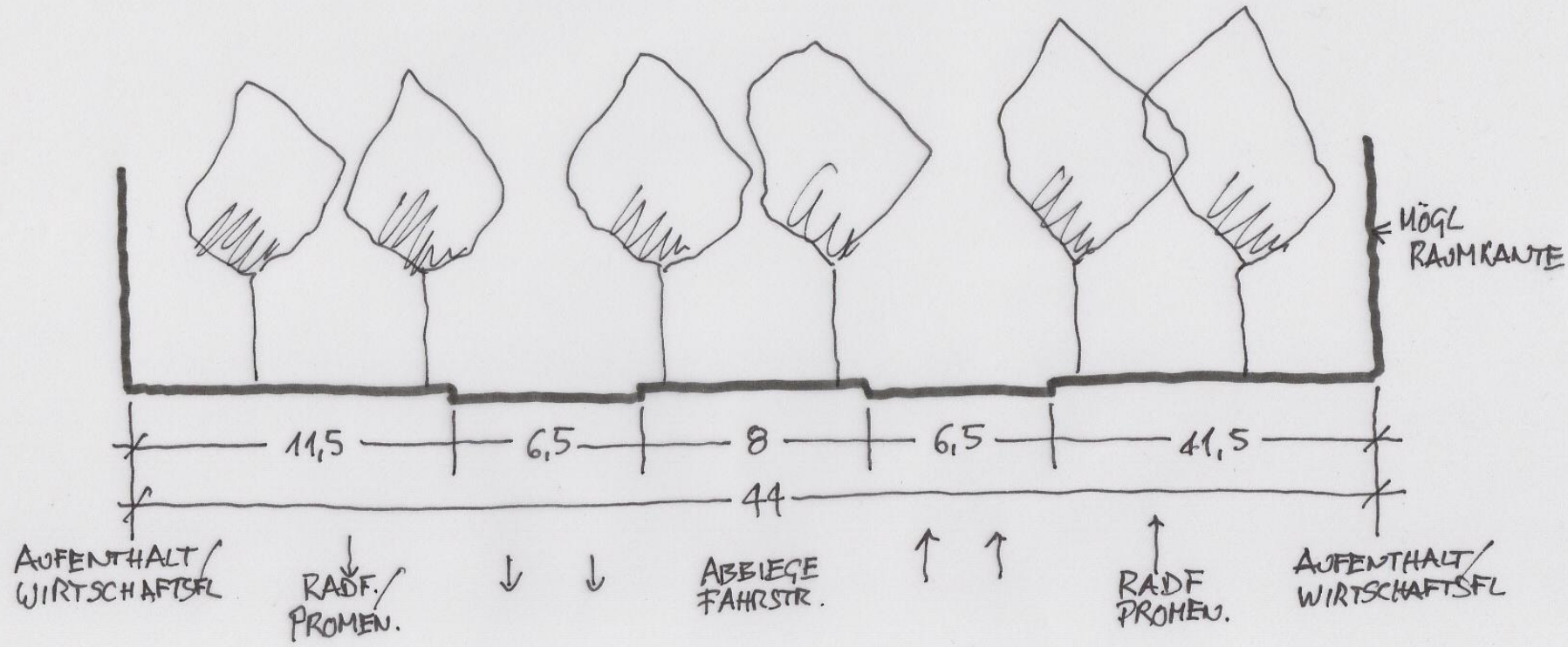



# Lärmschutz entlang Hochleistungsstraße durch Bebauung



Mittlerer Ring München

# Gestaltung von Rampenbereichen

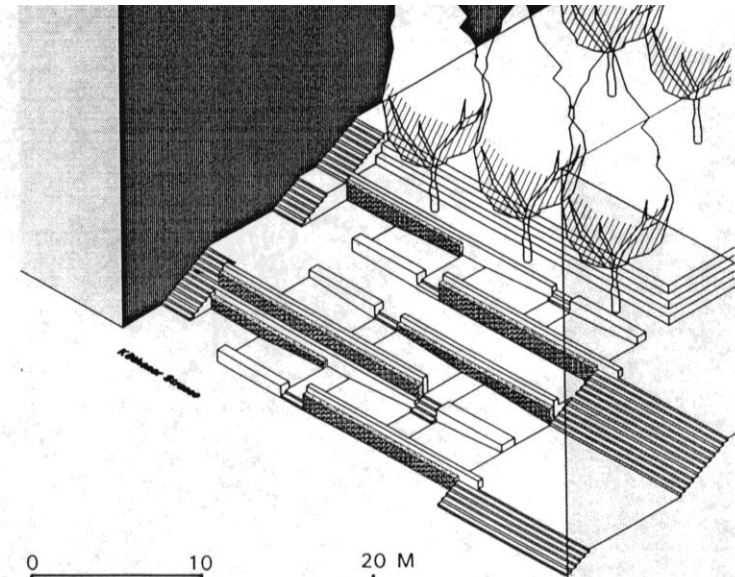
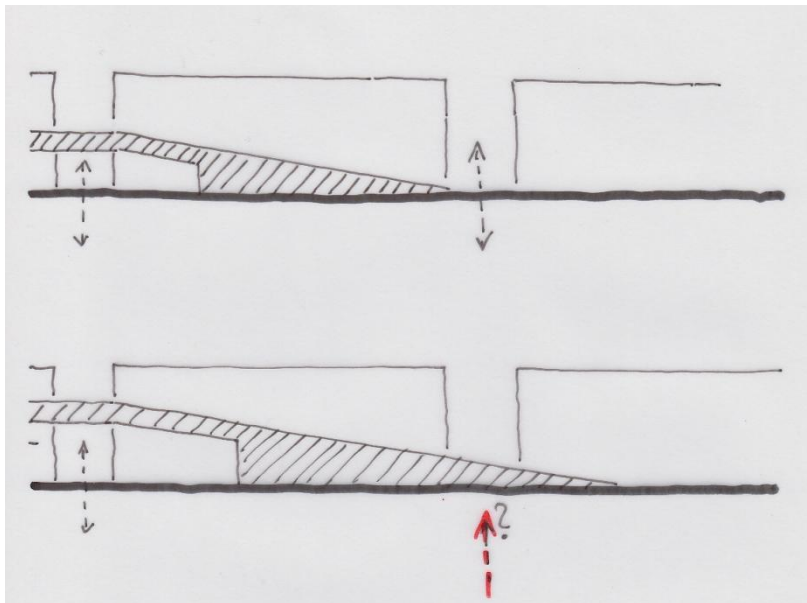
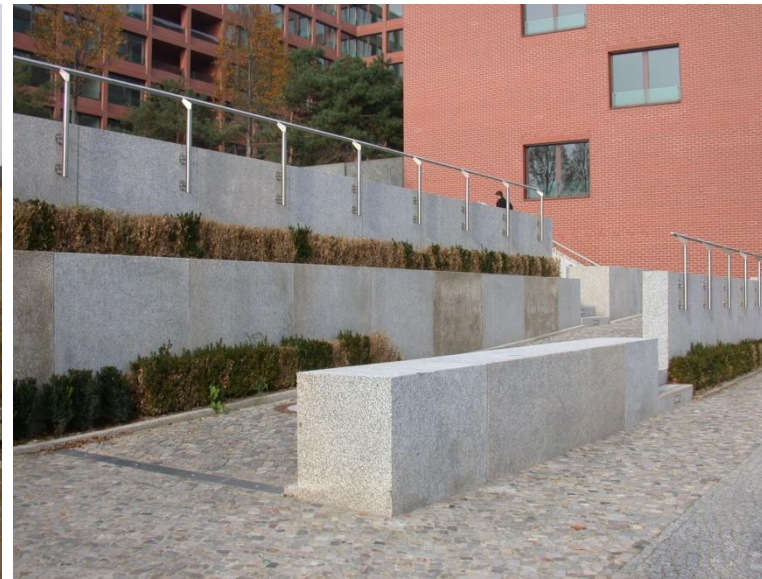

0 10 20 M  
Isometrie Köthener Str.